

(N108-F, N108-FC)		D (H)	S ()	T ()	C ()
NISSAN PATHFINDER 2004-...	N108-F	5,4	50	2200	750
	N108-F	10,2	100	2200	2000
D = g* TC/T+C					
S -					
T -					
C -					

80 / (N108-F, N108-FC) NISSAN PATHFINDER 2004-...
1000

28248-89 «
37.001.096-93 “

1.	2.
	(N108-F, N108-FC) NISSAN PATHFINDER 2004-... 1
	50 1
	17,6 1
	1

ФАРКОП.РФ

+7 (495) 669-38-36

(8)

12 80 (1)

(9)

()

1.

4.

.1 ()

N 108-F

1			
2	1	12 80	6
3	2	16 45	2
4	3	12	6
5	4	16	2
6	5	d 12	6
7	6	d 16	2
	7	F	1
	8		1
	9		1

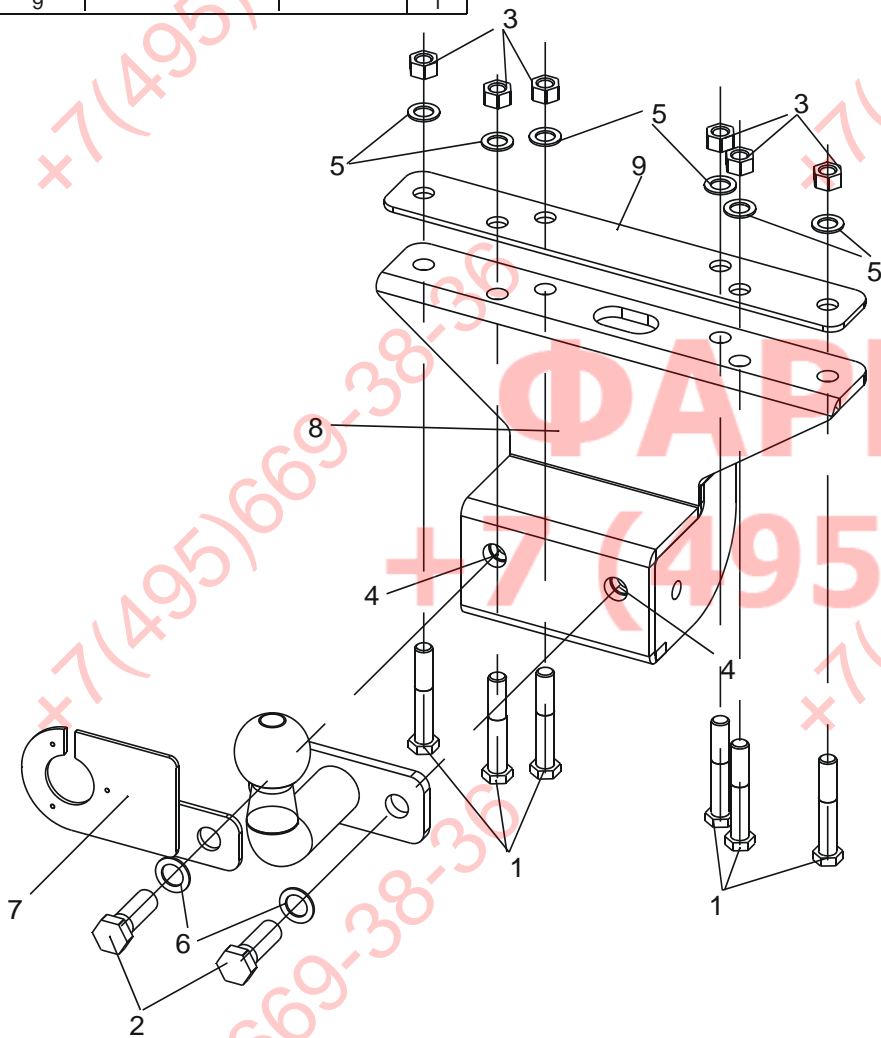

ФАРКОП.РФ

+7(495)669-38-36

+7(495)669-38-36